

AA3152 UTA

Installation Instructions

P/N 16-3152-001 Rev B 10/2022

Installing the AA3152 UTA on a Standard Gantry

For most overhead gantry installations, the AA3152 Universal Toll Antenna (UTA) is mounted on a 2- to 3-inch (5.0- to 7.6-cm) diameter pipe to accommodate various angles for lane tuning. Before installing the UTA, make sure you have the necessary items. Refer to [Table 1](#) for a list of parts for the UTA Accessory Kit (TransCore P/N 19011-01 or P/N 19011-03).

Table 1 Parts list for the UTA Accessory Kit

Quantity	Description
4	Spacers
2	U-bolts with hex nuts
2	Mounting brackets
12	Lock washers
4	Flange washers
1	Heat shrink tubing

Figure 1 shows the standard way to mount and connect a UTA.

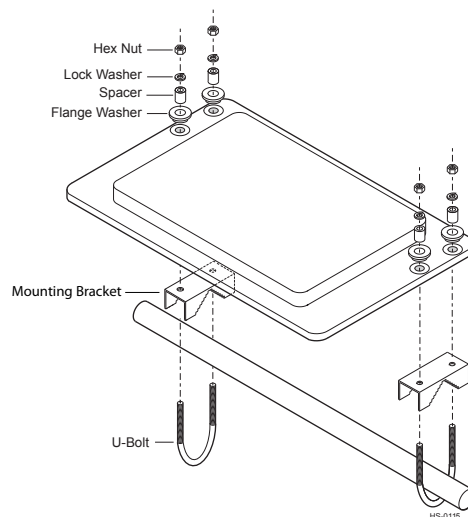

Figure 1 AA3152 Mounting Hardware



Caution

When installing the UTA, use only the mounting hardware provided

To install the UTA

1. This antenna is typically mounted toward the driver side of the traffic lane. Place the UTA, top side up above the mounting pipe, and insert a U-bolt around the pole and up through the mounting bracket on the side of the antenna closest to the center of the lane.

Note: The holes in the mounting bracket are not centered. Place the bracket so the narrow side is oriented toward the edge of the radome. Refer to [Figure 2](#).

2. Place the small side of each flange washer into each of the four (4) mounting hole on the radome. The large flat surface of the flange washer faces out. The U-bolt fits through the center of the flange washer. Place one (1) spacer, one (1) lock washer, and one (1) hex nut over each end of the U-bolt, but do not completely tighten the nuts. Repeat for the other U-bolt. [Figure 2](#) shows the correct placement order of the mounting hardware.

Note: Use of the spacer is optional. If the U-bolt is used with a larger diameter mounting pipe, the spacer may not be necessary.

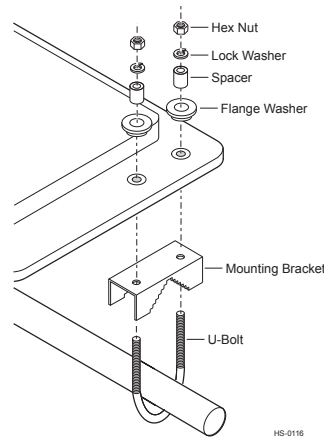

Figure 2 Mounting Hardware

3. Before tightening the nuts, rotate the antenna around the pipe so that the antenna is below the pipe. Next, angle the antenna up and toward oncoming traffic. Rotate the antenna up 15° nominal, or other specified uptilt angle from horizontal for each lane. Use an inclinometer or angle finder to verify the angles.
4. Tighten nuts with a torque wrench to 50 ft-lb (68 N-m).
5. The optional heat shrink tubing included in the UTA Accessory Kit is used for sealing the connection between the coaxial cable and the antenna.

For more information

TransCore Technical Support

Phone: (505) 856-8007

Web: www.transcore.com

TransCore Sales Support

Phone: (800) 923-4824